

API-200W, 300W, 500W, 1kW-VAWT
Installation and Operation Manual

Instructions for installation, testing and maintenance

for 200W-1KW vertical axis wind turbines

About the product

This product can be used by in any areas where has good wind resource, such as building roofs in cities, environment favorable buildings, and dependent small power stations in suburbs. It can provide stable and reliable electricity for lighting, household electrical appliances, beacon light, microwave communication, equipment, meters. It is ideal power supply equipment for families and companies.

Major components and working rationale

The whole unit consists of pillar, wind generator, storage batteries and inverter/controller. The Mill is pushed by wind at speed from 4m/s to 25m/s to rotate to make the generator produce power in AC form. Then the power will be changed into DC form by the charging controller to be saved in storage batteries. As last, DC power is changed into standard AC power through the inverter.

Connectivity instructions

Connect the batteries in series-mounting based on different voltages with the wires provided with the storage batteries. Then connect it with the corresponding terminal of the inverter/controller. Make sure all the contacts of the batteries and inverters are well connected. Anode end should be connected with anode end while cathode end should be connected with cathode end.

Installation instructions

1. How to find a good location

The product should be installed in a flat area with good wind resource, without big trees or building around. There should not be any buildings higher than the product within 30-meter area around it.

2. How to set up the foundation

Fix the base onto the concrete foundation according to the Figure of Foundation, and adjust the base to be flat. Curing period for the concrete foundation is 100 hours. Enough space should be given to lift the wind turbine unit. The central point of the generator to the inverter/controller should be less than 13-14 meters.

3. How to assemble the pillar and wind generator

Assemble the pillar and pilot set up

Lift the pillar to the base of the concrete foundation, to place and to the foundation bolts, then tighten all the nuts in turn.

Installation of the windmill

Installation process

- a) Connect the base with the generator, keeping them concentric, screwing tight with hexagon head bolts(M10X25) and spring washers($\Phi 10$), referring to drawing 1.

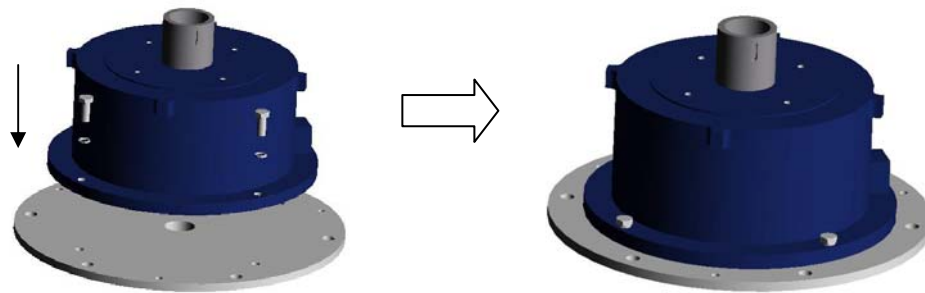

Drawing 1

- b) Connect the brake with the generator, also keeping them concentric, screwing tight with hexagon head bolts (M8X16), plain washer($\Phi 8$) and spring washer($\Phi 8$), referring to drawing 2.

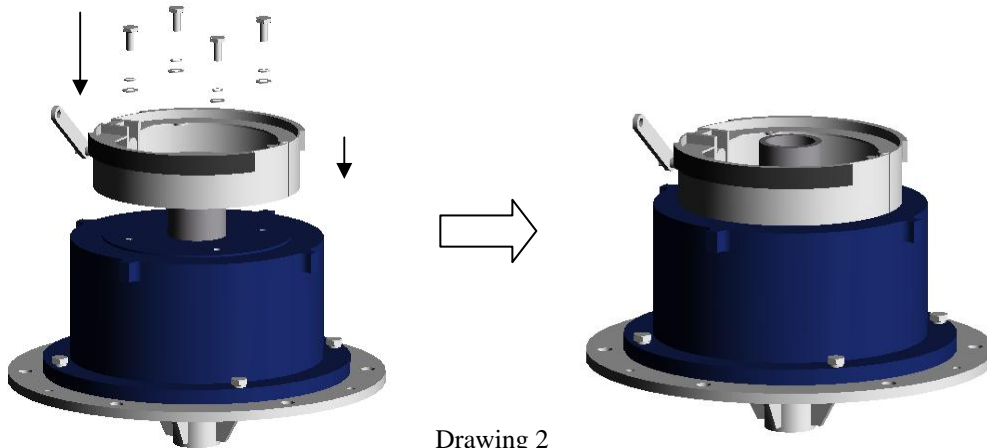

Drawing 2

- c) Put the keys(6X20) into the trough of the generator, and connect the inside track with the axis of the generator, referring to drawing 3.

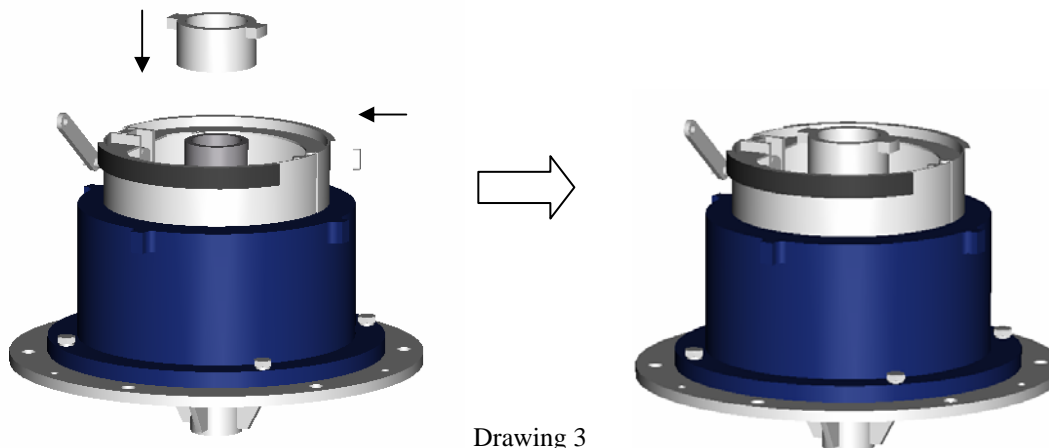

Drawing 3

- d) Put the keys(6X20) into trough of the axis, connect the nether flange with the main axis from the upper sleeve, and screw tight with screws(M6), referring to drawing 4.

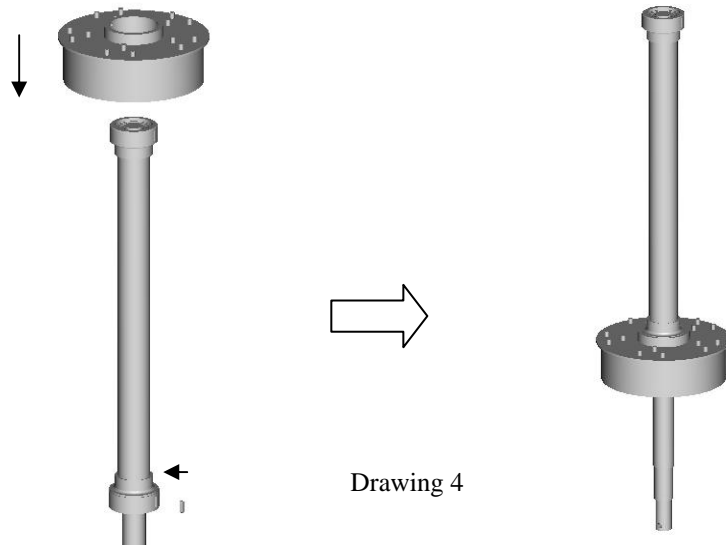

- e) Put the keys(6X20) into the trough of the axis, connecting the upper flange with the main axis, and screw tight with screws(M6), referring to drawing 5.

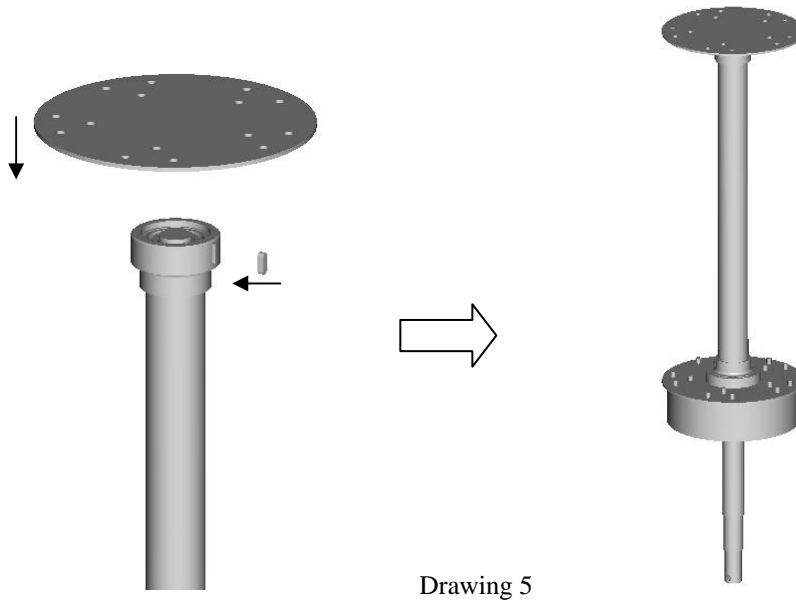

- f) Put the main axis through the generator, and screw tight with hexagon nuts (M30), plain washer(Φ 30) and spring washer(Φ 30), referring to drawing 6.

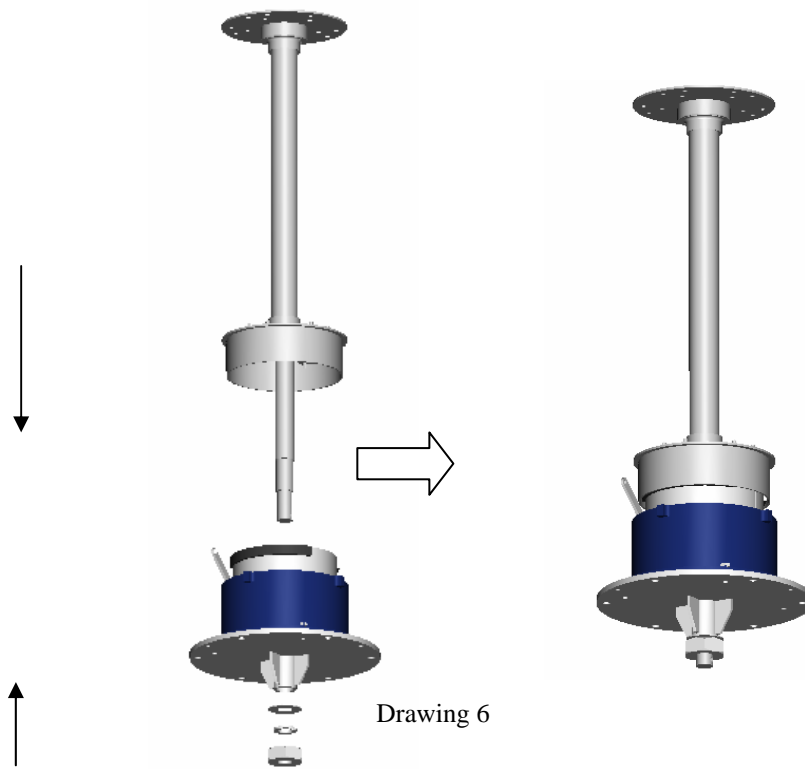

Drawing 6

g) Connect the blades with the sustaining arms, screw tight with bolts(M5X30), bolts(M5X50), spring washer($\Phi 5$)and locknuts (M5), referring to drawing 7. *The degree of tightness is on the condition that the hoops of the sustaining arms do not distort.*

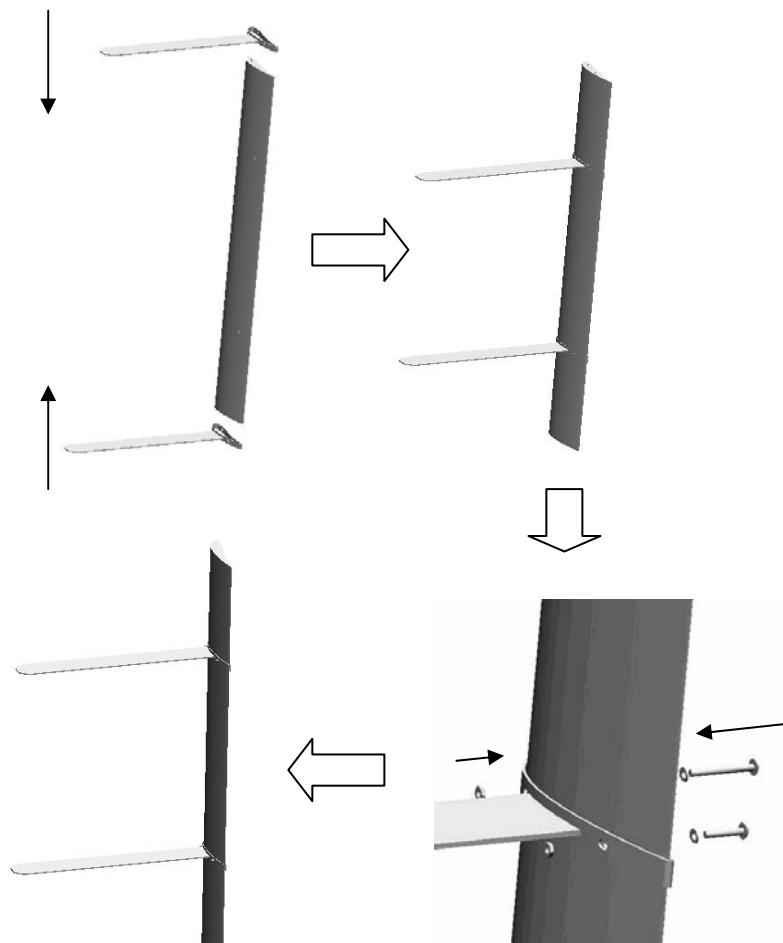

Drawing 7

h) Wipe silica gel onto the two side section of the blades, connect with the flaps and screw tight with bolts(M6X16), plain washer ($\Phi 6$) and spring washer($\Phi 6$), referring to drawing 8.

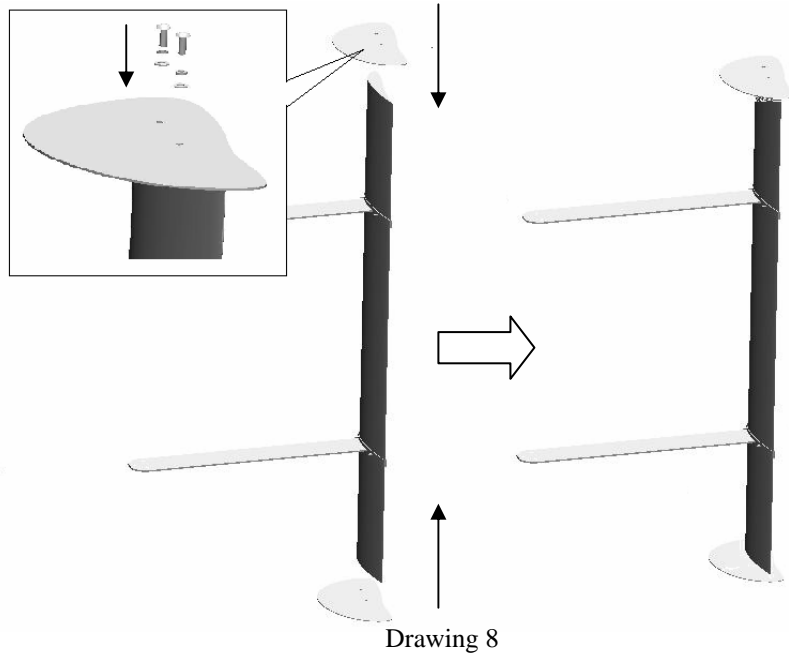

i) Connect the blades discretely with the upper and nether flange. **Move the blades discretely about, keeping the blades in uprightness and parallel to the axis.** Screw tight with bolts, plain washer($\Phi 8$), spring washer($\Phi 8$) and locknuts(M8). The installation process refers to drawing 9.

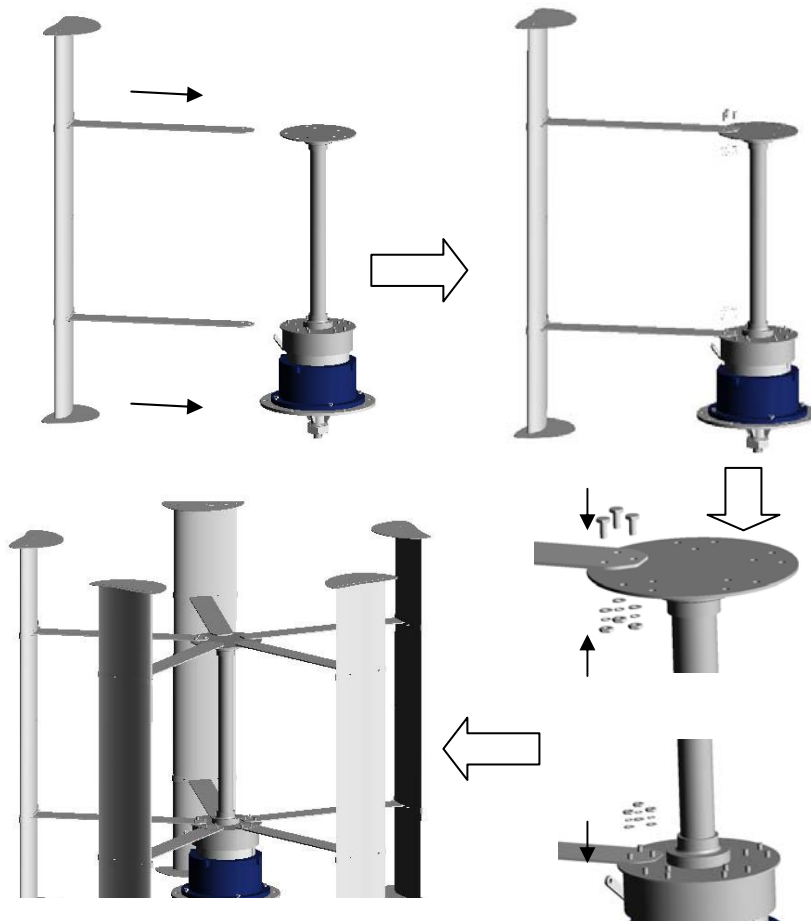

- j) Screw the lifting eye bolt (M8) into the base, and lift the windmill onto the pillar by crane. Make sure the stability of the windmill in the process of lifting in case of overturn, referring to drawing 10.

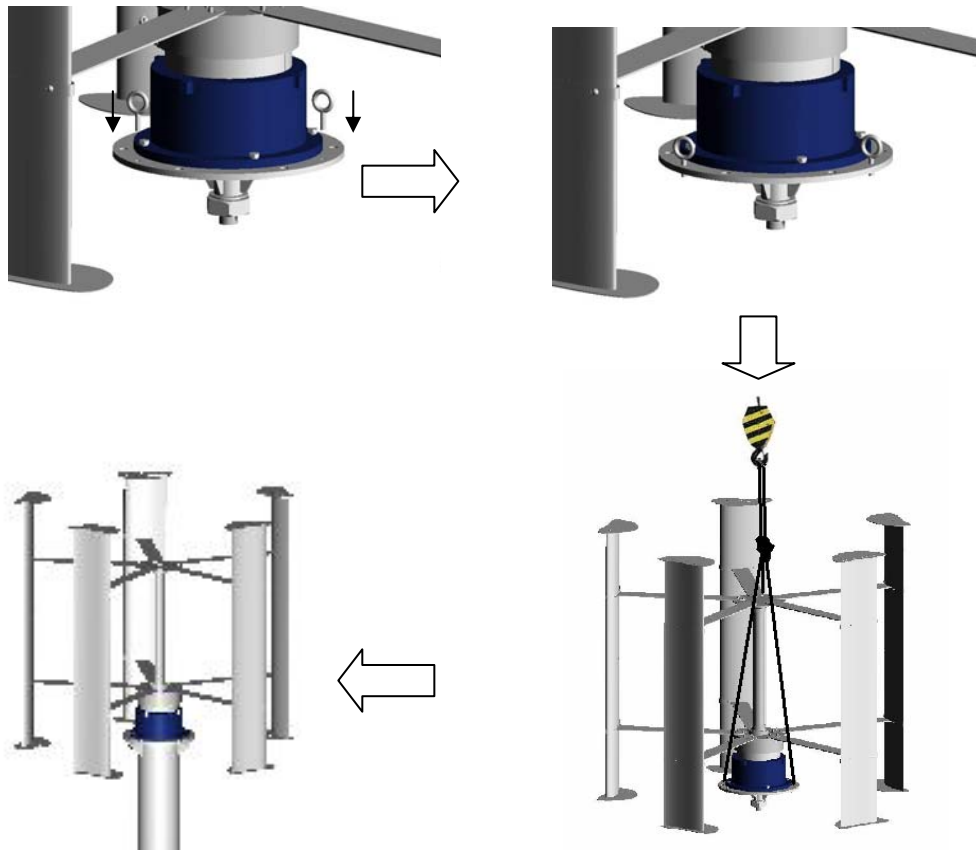

Drawing 10

- k) Connect the base with the pillar, and screw tight with bolt(M12X40), plain washer(Φ 12), spring washer(Φ 12) and locknuts(M12), referring to drawing 11

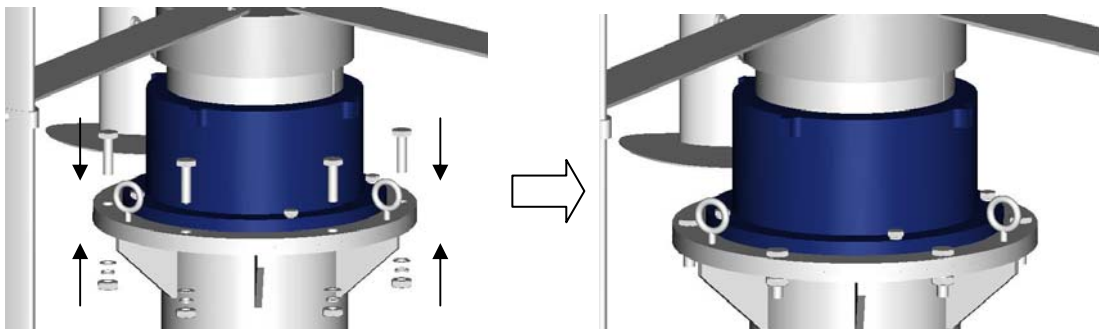

Drawing 11

Installation complete, referring to drawing 12.

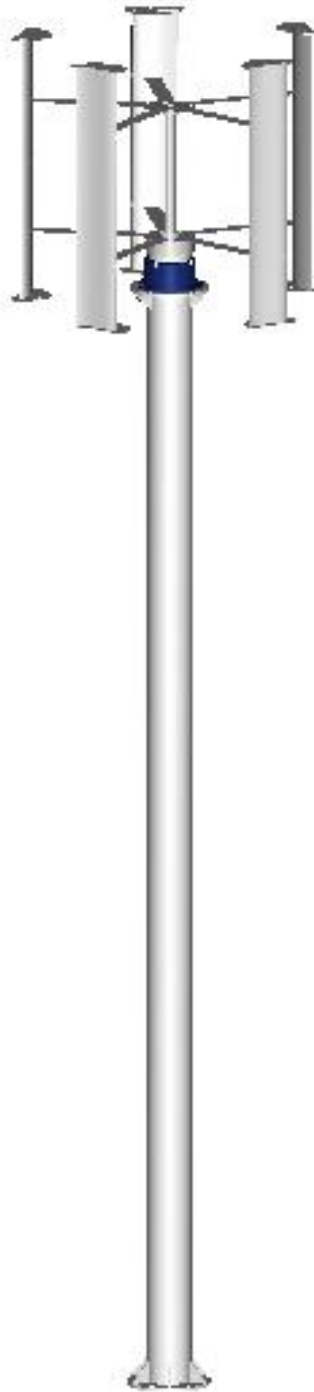

Drawing 12

Note: All bolt joint points must be coated with thread locking glue.

4 Testing

1. Check all the bolts before the testing to make sure they are all securely tightened.
2. Turn around the mill slightly with hands to check if there is any collision. Fix it there is.
3. For off-grid use, connect all the wires: connect the generator, controller/inverter and the storage batteries with cables provided as shown in Drawing 13. For in-grid use, connect the generator, controller/inverter and grid as shown in Drawing 14.

To avoid danger and accident, installation should not be conducted when there is strong wind.

Off grid system connecting

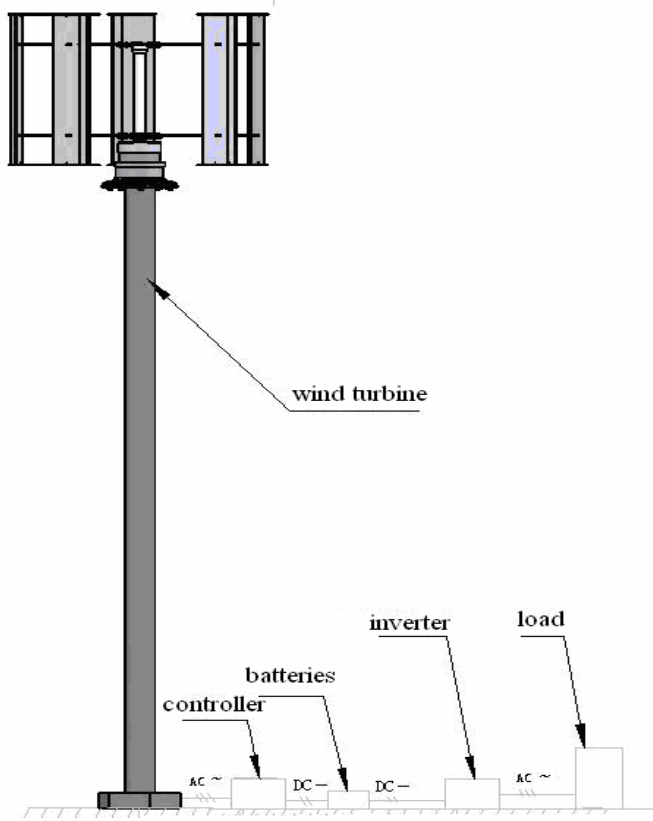

Drawing 13

On grid system connecting

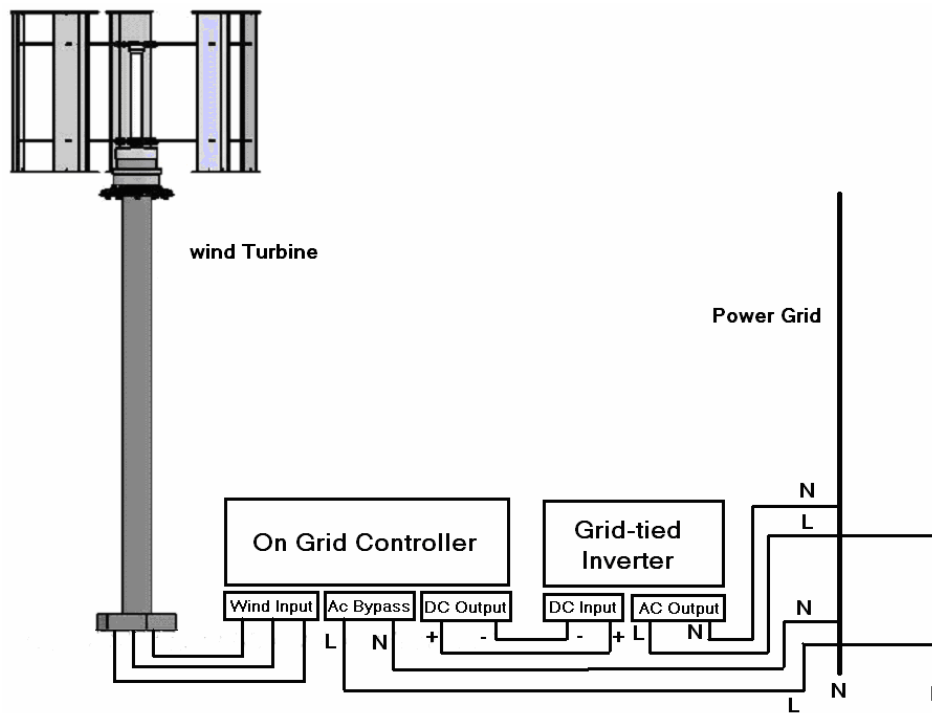

Drawing 14

Instructions on maintenance

1. Appropriate and timely maintenance of the system is directly related to the performance and life cycle of it. Key points are:

- Inspect, clean and lubricate all the rotating parts once a year.
- Clean, derust and paint all the exposed parts in every two years.
- Frequently check the tension of the cables of the pillar. When any of them get loose, they should be fastened promptly.

2. Other reminders:

- Use brake to stop the turbine working when the wind speed is over 25m/s.
- Inverter/controller should be placed in a dry, ventilated and non-polluted environment. **Read carefully the manual of the controller and the inverter.**
- The storage batteries will leak certain amount of caustic gas, so they should be placed in a ventilated area without flames.
- It is forbidden to leave anything on the terminals of the storage batteries to prevent short circuits.

Troubleshooting

Problems	Causes	Solutions
Abnormal noise	<ol style="list-style-type: none"> Fastened parts are getting loose Connection between the bearing of the generator and the base is getting loose The bearing of the generator has been damaged Mill rubs with other parts Rotor and stator rubs with each other 	<ol style="list-style-type: none"> Check the loose parts and fasten again Find out the exact point and fix it Change the bearing Inspect and fix it Repair the rubbing points
Rotating speed of the mill is obviously decreasing	<ol style="list-style-type: none"> Rotor and stator rubs with each other Short circuit occurred in rotor winding The Switch is in the Off position 	<ol style="list-style-type: none"> Disassemble the generator to restore the specification data in the magnet. Find out the point with short circuit to peel off and insulate Put the switch into On
Output voltage is low	<ol style="list-style-type: none"> Rotating speed of the generator is low Permanent magnet rotor is demagnetized. Short circuit exists in the stator winding Slip ring in power transfer and joints of output wires are not conducted Low voltage power line too long, wire too slim 	<ol style="list-style-type: none"> Find the causes to restore the normal speed Change the rotor Find out the point, and paint it to insulate Clean the slip ring and joints to decrease contact ring brush Shorten the wire or enlarge the wire diameter to decrease lost in transferring
No output currents from the	<ol style="list-style-type: none"> Output wire is broken Stator winding burned and caused broken 	<ol style="list-style-type: none"> Find out the point and reconnect disassemble and fix
AC output is, but no DC	<ol style="list-style-type: none"> DC safety belt broken 	<ol style="list-style-type: none"> Change the safety belt

output	2. Output wire is broken 3. Rectifier is damaged	2. Find out the point and reconnect 3. Change the rectifier
Output capacity of the storage batteries is not enough	1. Output voltage is too low from the generator, or no power 2. Terminals of the storage batteries are acid etching, conductance broken 3. Storage batteries expired	1. Refer to the solutions for Problem 3 2. Clean the joints, fasten the connection and apply protection oil 3. Change the batteries

Warranty statement

1. Warranty period is one years starting from the date in the shipping bills. Warranty Card and shipping bills will be required for warranty services.
2. In the warranty period, any of the below problems occurred due to manufacturing quality, exchange for new parts and reparation is free.
 - a) With normal use of the product, power generating is abnormal due to rotor stopping working, short circuit in stator, the generator will be replaced.
 - b) With normal use of the product, brokenness happened on exterior shell of the generator and the base which may affect the performance of the system. The part will be replaced.
 - c) With normal use of the product, blades that fell over will be replaced.
 - d) With normal use of the product, because of quality reason, the weight-holding part of the pillar has tip off, it will be replaced or repaired at the option of Aeolus.
3. Aeolus will charge for repair and replacement of parts when warranty does not cover any other problems including those that arise as a result of,
 - a) Components fall down or damaged because animals bump, bite, push or pull the pillar, cables and other parts.
 - b) Damages to the blades because stopping the mill in wrong measures, e.g., with a wood pole to stop the blades. Or some parts get broken because of improper operating when the system is running at a high speed.
 - c) Problems occurred because moving the product or changing the installation methods and locations at one own will.
 - d) Damages due to force majeure, e.g., earthquake, sand storm, strong hail, hurricane, typhoon, thunder strike, replace and repair will be charged.

We guarantee our equipment can be used at least 20 years when it has been used normally.

Note: Make sure that you install the turbine when the wind speed is under 7m/s.